

FIX UP/ FIX DOWN

A FIX UP / FIX DOWN SCENARIO IS AVAILABLE IN SOME INSTANCES BUT ONLY AFTER FULL SITE SURVEY BY AN LBS GROUP REPRESENTATIVE AND IS ACHIEVED USING A HEAVY DUTY SQUARE SECTION STEEL.

ALL SUPPORTING STRUCTURES ARE EXISTING OR BY OTHERS. FULL WIDTH ACCESS SHOULD ALWAYS BE AVAILABLE FOR SERVICE, REPAIR OR MAINTENANCE PURPOSES. POSITION AND RATING OF SUPPLY IS DEPENDANT ON CLIENT SPECIFICS WHICH SHOULD BE RELAYED TO LBS AT EARLIEST OPPOTUNITY FOR QUOTING AND PLANNING PURPOSES. WEIGHTS ARE CALCULATED DEPENDANT ON CONFIRMATION OF DIMENSIONS.

THIS INSTALLATION WILL BE MANUFACTURED IN CONJUNCTION WITH A SUITABLE INBOARD OR OUTBOARD FLANGE MOUNT WITH RELEVANT GEARING.

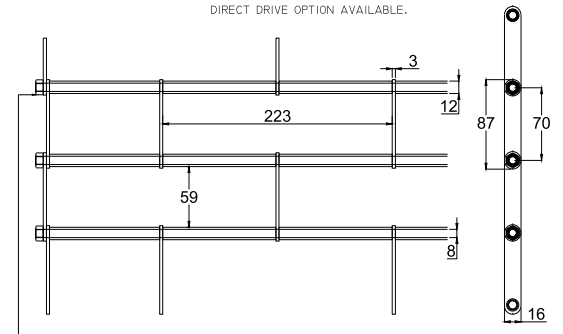

M8 Nut welded off

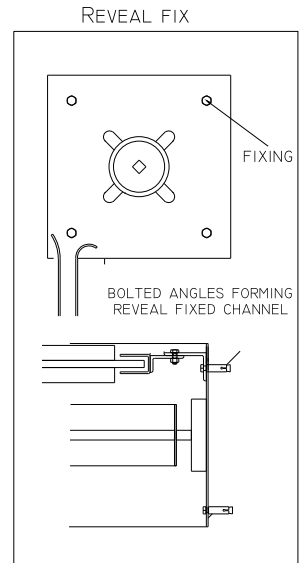
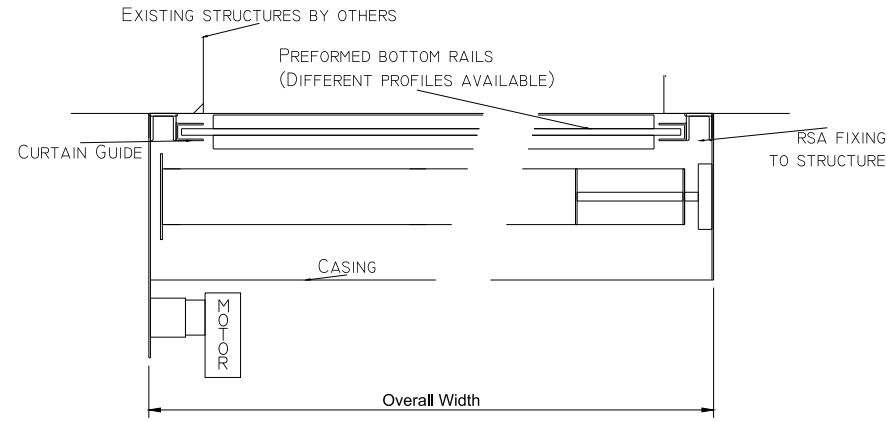

| Fixing Guidance | |
|-----------------|--|
| Steel | M6-M10 Set screws or Hex bolts |
| Masonry | M8-M10 Rawbolts/ Sleeve anchors |
| Timber | 12swg screws / M8-M10 Coach screws |
| Concrete | 12swg screws / M8-M10 Rawl bolts or Sleeve anchors |

| Headroom Guidance | |
|-------------------|---------------------------------|
| Height | Endplate Height (ordinary coil) |
| <1200 | 255 |
| 1200>2400 | 305 |
| 2400>3000 | 305 |
| 3000>3600 | 380 |
| 3600>4200 | 425 |
| 4200>4600 | 450 |

THE ABOVE DIMENSIONS ARE IN MILLIMETERS AND ARE THE MINIMUM AVAILABLE. REVERSE COILING THE CURTAIN WILL INCREASE THE HEADROOM REQUIRED. CORRECY UPTO 4.5. WIDE. FOR DIRECT DRIVE MOTOR PLATES SEE DDO PLATE TECHNICAL DRAWING.

HEAVY DUTY PORTCULLIS GRILL
 COMPRISED OF ALLUMINIUM TUBE AND LINK COMPLETE WITH 8MM STEEL ROD CORE. ALLOWS 80% FREE AIR FLOW. THIS SYSTEM IS TYPICALLY A 400V OUT BOARD MOTOR, EITHER DIRECT OR GEARED, AUTOMATED DRIVE. THE SYSTEM WILL COME STANDARD WITH THE FULL COMPLEMENT OF SAFETY SYSTEMS TO PROTECT THE USER AND THIRD PARTIES. THE SAFETIES CONSIST OF HIGH LEVEL ANTI ENTRAPMENT SENSORS (COMPULSORY), AND DEPENDING ON HIGHT RESTRICTIONS, LOW LEVEL AUTO RETRACTING PHOTOCELL BEAMS INTERNAL AND EXTERNAL WITH AUTO RETRACTING SAFETY EDGE FOR OPENING WHERE HIGH IS NOT A FACTOR. WHERE CLEARANCE IS A FACTOR A SINGLE AUTO RETRACT LIGHT CURTAIN SYSTEM CAN BE PROVIDED.

THE DIMENSIONS ARE FOR GUIDANCE ONLY SIDEROOM CAN INCREASE DEPENDANT ON SPECIFICATIONS REQUESTED BY THE CLIENT

The above guidance dimensions are subject to site surveys carried out by an LBS Group representative in conjunction with the correct specifications supplied by our client.

PRODUCT: LBS HEAVY DUTY CAR PARK BRICK BOND GRILL

DATE: 12.12.2019

DRAWN BY: JS

LBS GROUP GENERIC DRAWINGS

REVISION No: 1 A
 DRAWING No: LBS013

Approved:

LBS GROUP
 UNIT 6 STERLING
 INDUSTRIAL ESTATE
 RAINHAM ROAD
 SOUTH
 DAGENHAM
 ESSEX
 RM10 8TX

